

Bu Resim MESA OTO ELEKTRİK LTD.ŞTİ'nin malıdır. Şirket Yetkililerinin izni olmaksızın kopya edilemez, üzerinde değişiklik yapılamaz.  
This image MESA AUTO ELECTRIC LTD.'s are property. Can not be copied without the consent of the company authorized, any changes can be made.

PARÇA KODU PART CODE	PARÇA ADI PART NAME	s ÖLÇÜSÜ (KALINLIK) s MEASURE (THICKNESS)	Malzeme Material	Kaplama / Coating		
				SN	AG	Nİ
TŞ 2430 DP	10 NO KABLO UÇ Ø10.5 =DP=	-----	(CuZn30) Pirinç / Brass	-	-	-
TŞ 2430 RP	10 NO KABLO UÇ Ø10.5 =RP=	-----	(CuZn30) Pirinç / Brass	-	-	-
TŞ 2430 RPK	10 NO KABLO UÇ Ø10.5 =RPK=	-----	(CuZn30) Pirinç / Brass	+	-	-

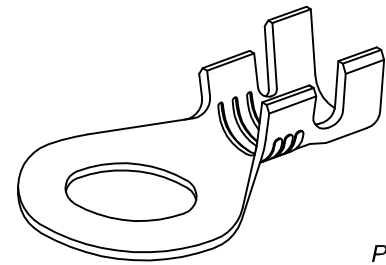
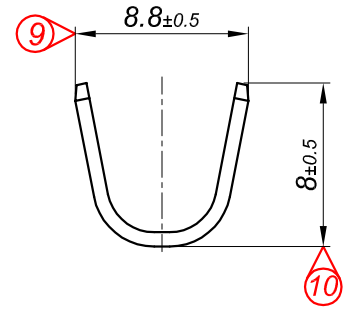
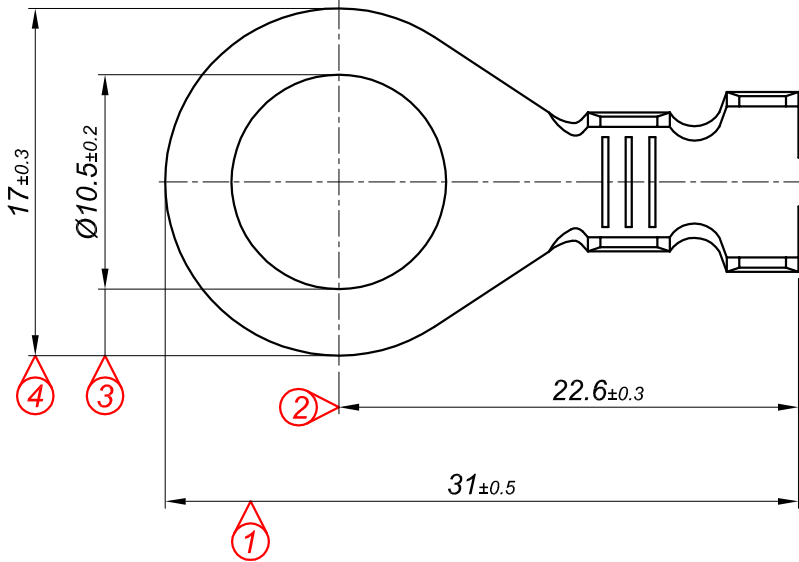
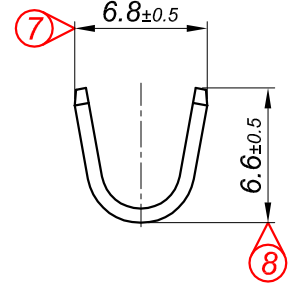
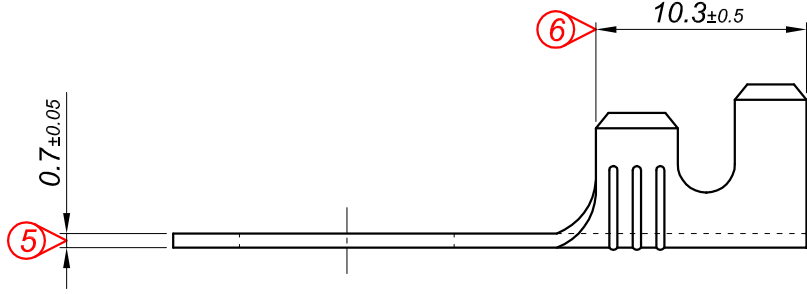

Perspektif  
Perspective

Kalıp çıkış yönü  
Mold output direction

Makara açılım yönü  
Reel opening direction

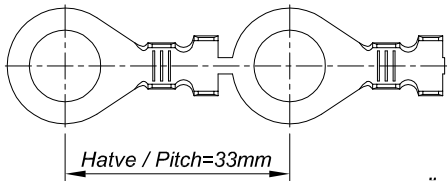

Ölçek  
Scale : 1 / 1

Kablo Kesiti

Wire Section : 4 - 8 mm<sup>2</sup>

Resim üzerinden ölçü almayınız  
do not measure on drawing

Tarih / Date	25.07.2013	İmza / Signature	Ölçek / Scale			
Çizen / Desing	M.Yağcı		3 / 1			
Onay / Approval	S.Gölcük		No		Değişiklik / Revision	Tarih/Date
	Parça Adı: Part Name	10 NO KABLO UCU Ø10.5			Parça Kodu: Part Code	TŞ 2430